



OUR COMPREHENSIVE SERVICE FOR YOUR SUCCESS IN SALES

nobilia – Your partner for kitchens, bathrooms and living rooms.

nobilia[®]

Expertise

Quality

Humanity



From the left:

Bernd Weisser, Director Domestic Sales and Matthias Keudel, Director Export

YOUR PARTNERS FOR A PARTNERSHIP OF EQUALS

Joint success depends on mutual trust. This trust grows from shared values and goals. This brochure is our invitation to you to get to know us better.

We are a market leader for kitchens in Europe with more than 80 years of experience. But we are more than just a large kitchen furniture producer. We are a system supplier for the entire home, and offer our retail partners extensive, unique services along their entire value chain, far beyond just furniture.

So what are the advantages we offer you? The following pages will show you what defines us and what we represent. They will show you an exciting glimpse into the world of nobilia.

We hope you enjoy the experience.

Bernd Weisser

Matthias Keudel

THREE UNIQUE FEATURES

ONE RELIABLE PARTNER FOR YOU

Expertise

Since the early days of our company in 1945 we have become not just one of the largest, but also one of the most expert and influential, manufacturers of high-quality kitchens worldwide. Our thoroughly substantiated expertise allows us to remain closely connected to the market, to our customers and to the needs of consumers. That is why the furniture we develop is exactly what customers want. Our furniture is perfect for their lifestyle – in the past, present and future. With nobilia, anyone can find the right interior design solution to meet their needs. Innovation at nobilia is not just for products, but also for production processes, services or market support. We measure our success not just in large production quantities, but mainly in the high satisfaction rates among our customers.

Quality

At nobilia we manufacture furniture with first-class quality and sustainability standards, exclusively made in Germany. All employees of our company are dedicated to these goals in their daily work. We process high-quality materials, make use of state-of-the-art technologies and work with passion, developing our products and services to offer our customers solutions tailored precisely to their needs. Numerous coveted awards and seals of quality prove how seriously we take these goals.

Humanity

Collaborating with nobilia means feeling appreciated as a partner and entering into a dialogue of equals. We practise this approach not just in communication with our customers, but equally inside our team. As a family-owned company we foster a culture of closeness, defined by trust, openness and mutual respect. This personal interchange gives us a comprehensive understanding of the multi-layered needs of our customers and our employees. That allows us to improve all the time and lets us offer you the best possible service.

A GOOD CHOICE

1 A FAMILY-OWNED COMPANY

- 1.1 Made in Germany for the whole world 8
- 1.2 Innovative energy since 1945. Milestones of company development 10

2 KITCHEN EXPERTISE

- 2.1 Kitchen versatility in design and function 14
- 2.2 Design meets technology 16
- 2.3 Perfect planning – limitless options 18
- 2.4 Unique innovations – award-winning quality 20
- 2.5 Marketing from a single source 22

3 COMPREHENSIVE FURNISHING SOLUTIONS

- 3.1 A system supplier for more than kitchen 26
- 3.2 Your reliable partner for living and dining rooms 28
- 3.3 Product diversity and quality for bathrooms 30

4 COMPREHENSIVE SERVICE FOR OUR PARTNERS

- 4.1 Business success through extensive support 34
- 4.2 From brand experience to sales success 36
- 4.3 Relevant content for greater reach 38
- 4.4 Limitless options thanks to digital solutions 40
- 4.5 The nobilia retail concept 42
- 4.6 Perfectly planned showrooms by our experts 44
- 4.7 Large building projects with a system 46
- 4.8 Overcoming the challenges of the future through training and professional development 48
- 4.9 Practical training for assembly teams 50

5 SAFETY THROUGH QUALITY

- 5.1 Top quality from the get-go 54
- 5.2 Innovative production with a system – Made in Germany 56
- 5.3 Customised furniture in serial production 58
- 5.4 Delivery with top reliability 60
- 5.5 Shaping a sustainable future 62

6 BECOME OUR PARTNER

- 6.1 Your advantages at a glance 66

1

A FAMILY-OWNED COMPANY





“For us as a family-owned company, acting globally means taking personal responsibility, and working with motivation every single day.”

Dr. Lars M. Bopf,
Chairman of the board

A FAMILY-OWNED COMPANY MADE IN GERMANY FOR THE WHOLE WORLD

Welcome to nobilia

Passion for excellent products and top-quality service, for innovative ideas and sustainable economic activity: That is what motivates the over 4,500 people working for us, every day. This attitude is the foundation of our success. We are Europe's leading manufacturer of fitted kitchens and are one of the largest producers of customised kitchens worldwide. We manufacture our furniture in a total of four plants, all of them in Germany, and export it to around 90 countries. Top-level standards in quality, service and sustainability are indispensable for us.

Being a family-owned company gives us the freedom to shape our future in the long term, sustainably and independently. It allows us to adapt our development systematically to the market and our retail partners' requirements. Moreover, the concept of family is at the core of our corporate culture and runs through our history like a thread. We remain a family-owned company to this day and feel at home at our locations in Verl, Gütersloh and Saarlouis.

8.5 million kitchens per year – for unique furniture

With our kitchens, there is no limit to our customers' creativity and joy in combining options – both in the design and in the equipment. Our selection of fronts, colours, worktops, electrical appliances and accessories is captivating in its versatility. We make sure everyone gets exactly the kitchen that meets their needs. Our product range reaches broad groups of consumers – through diversity in styles, price classes and material types. For several years, we have also been offering fully coordinated living and furnishing concepts for every room in a home with this exact approach. The one thing all of our solutions for kitchens, bathrooms and living rooms have in common is compelling quality at attractive prices.

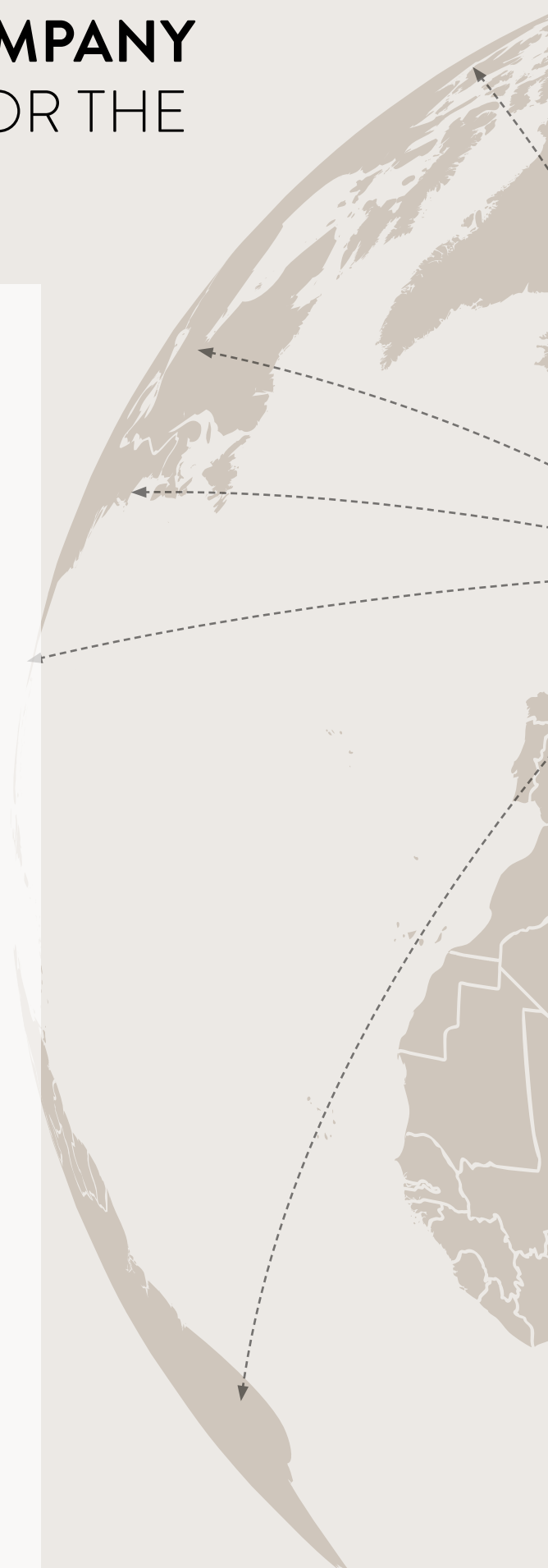



- We are the market leader for kitchens in Germany and Europe.
- Independent action and entrepreneurship define our family-owned company.
- Our product range is fully adapted to the demands of the market.

Verl, Gütersloh
Plant I, II & III

Saarlouis
Plant V

1.659 billion€

Total turnover in 2022

8,500,000

kitchens per year

~90

export countries

4,523

employees

54%

export rate

~9,000

retail partners around
the world

INNOVATIVE ENERGY SINCE 1945

MILESTONES OF COMPANY DEVELOPMENT

First there was occasional furniture. Next came kitchen buffets. And 1967 saw the arrival of fitted kitchens. These were the beginnings of nobilia's history as a brand. In the region of East-Westphalia in the north-west of Germany, a rapid development began, eventually turning nobilia into the largest manufacturer of fitted kitchens and market leader in Europe. Today, our company looks back at over 80 years of success. Our history is defined by being proudly family-oriented, by traditional craftsmanship, the East-Westphalian down-to-earth attitude, forward-looking decision-making and courageous entrepreneurship.

1967

From now on, nobilia specialises in fitted kitchens.

1970

What is now Plant I is built in Verl-Sürenheide, with a size of then 51,000 sqm.

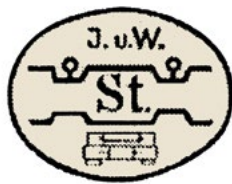

1945

Foundation of the Johann and Willy Stickling OHG by master carpenter Johann Stickling and tradesman Willy Stickling, employing seven people.

1973

nobilia's first in-house exhibition takes place in an exhibition space of 2,000 sqm in Verl-Sürenheide.

2006

Launch of Plant II in Verl-Kaunitz.



2021

Launch of the two new plants in Gütersloh (Plant III) and Saarlouis (Plant V).



2024

The launch of the innovative nBOX in 2024 is the largest product campaign in the company's history and sets new standards in design and technology for serial production.



THIS IS
WHAT
DEFINES
US.

2018

more than kitchen. For the first time ever, nobilia presents coordinated living room concepts and its own range of bathroom furniture.

2022

Opening of the factory's own bridge across the A2 (motorway), connecting Plant I and III.

2

KITCHEN EXPERTISE





“Kitchens are a holistic matter for us: we have passion for function, design and quality.”

Michael Dohmen,
Deputy Head of Exports

KITCHEN VERSATILITY IN DESIGN AND FUNCTION

Kitchens are our special passion – and have been since the earliest days of our company history. With more than 80 years of experience, we represent top quality, innovation and reliability. People's needs in life and visions of a personalised home are in constant flux. Predicting these desires and quickly turning them into design and function is what we view as our key task.

Range with a system. Designs for the future.

nobilia considers customer satisfaction the top priority whenever we develop a collection. Our kitchen systems combine a modern design language with high quality and sophisticated function. Every year we expand our collection with trendy and innovative products – for kitchens that fit into our customers' lives all around the world. In-house, partly patented product developments and exclusive partnerships create unique selling points in furniture and accessories. This means nobilia gives its partners clear options to create a distinctive image for themselves. Our product range intends to reach around 80 percent of the market – in terms of styles, material types and surfaces as well as pricing. nobilia develops its product range precisely for this broad market reach, therefore offering exceptional versatility – from modern minimalism through timeless classics to a contemporary cottage style.



High quality and
a long life with more than
80 years of kitchen expertise



Large variety for
broad target groups
and price segments

DESIGN MEETS TECHNOLOGY

Our versatile range of fronts is key to the overall appearance – design, feel and durability, either with or without ant-fingerprint coating. Below we present a small excerpt of our special product features – but, of course, our product range offers much, much more for you. It's not just what's on the outside that counts: Our exclusive nBOX drawer system is an innovation nobilia developed in-house to set new standards for the design of unit interiors. It lets you offer your customers premium design and technology as a serial standard at attractive prices.

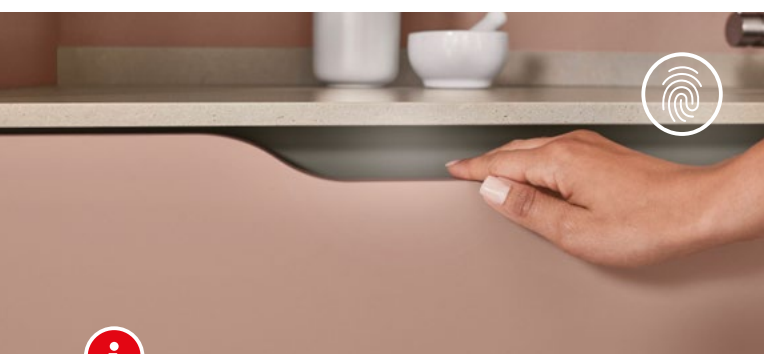

A flawless kitchen – anti-fingerprint makes this dream a reality

Elegant matt fronts without visible fingerprints: That is exactly what nobilia's anti-fingerprint coating achieves. A microscopically fine, UV-cured surface seals the front, preventing fingerprints from sticking. The result is a visibly cleaner surface requiring significantly less cleaning. On top of that, the coating makes the surface particularly robust and scratch-proof. The kitchen remains flawless for much longer – a perfect combination of design and function.



You can find more information about our anti-fingerprint fronts at: <https://www.nobilia.de/en/anti-fingerprint/>



Perfect beauty, without fingerprints: Anti-fingerprint fronts

Anti-fingerprint fronts are available in multiple nobilia front ranges. SENSO is all about clean colours, a soft feel and robust surfaces in colours such as Sky, Coral or Slate grey. EASYTOUCH offers ultra matt fronts with an intense depth of colour and pleasant feel, e.g. in Rust red, Mineral green or Fjord blue. SOFTLINE combines classy honed lacquer in Perfect honed with hues such as Alpine white, White and Ivory. The modern cottage style range FRAME complements the anti-fingerprint range just like NATURA and individual fronts in the SYLT and NORDIC ranges. Great design is not all about great looks, it is also about everyday life.

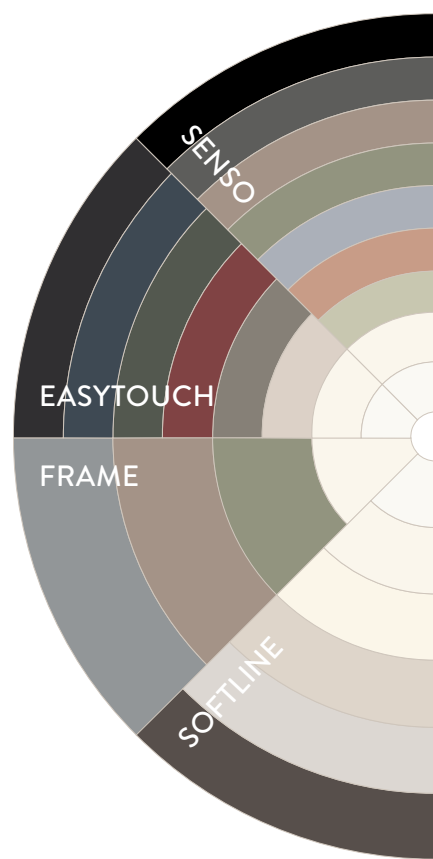



More information
about the nBOX at:
<https://www.nobilia.de/en-nbox-qr>



The exclusive nBOX drawer system – a strong design with clever details

nBOX is more than just an innovative design. The straight-lined look in classy slate grey melds seamlessly into the overall style of the furniture and is perfect for coordinating designs in kitchens, bathrooms and living rooms. The concealed drawer guide and the optional push-to-open function leave nothing to be desired where convenience and technology are concerned.

Designed in straight lines. Fashioned for versatility.

A frame of only 10.7 mm width gives the drawer an airy look and creates clean lines in kitchens, bathrooms and living rooms. In the trend colour Slate grey, with modular elements such as glass sides, angular railings or a closed pull-out box, the nBOX is a truly innovative system component. The available options include design profiles or design covers – both add stylish colour elements, meld seamlessly into the furniture design and offer amazing freedom of design. Both the design profiles and the design covers are easy to clip on and retrofit, permitting customised solutions with minimal effort.

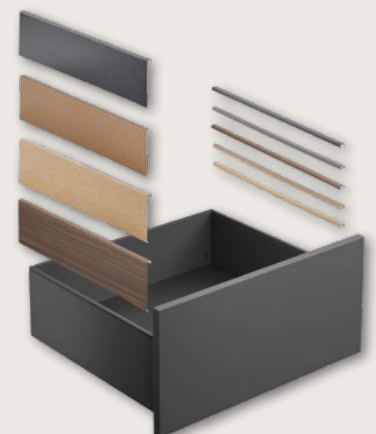

MORE DESIGN. MORE COMFORT. MORE CHOICES.

PERFECT PLANNING LIMITLESS OPTIONS

We set standards for innovation and convenience. From style-defining product designs through forward-looking technologies to sustainable solutions – continuous, consistent optimisation is at the heart of nobilia's philosophy. Our clever systems make kitchen planning simple and efficient, and give you certainty. Tailor-made solutions, flexible design options and innovative products don't just make planning easier, they also create kitchens that are perfectly adapted to the customer's individual needs. This ensures your success in the long term, allowing you to impress your customers with excellent quality and design.

n144
the living system

Custom-fit planning

The grid system n144 lets you plan nobilia kitchens in a custom-fit, ergonomic manner with fully compatible lines. It makes kitchen planning simpler, and practically does away with the need for specially made products. It also permits design-oriented plans with customised storage room planning and user-compatible working heights. This grid system is the perfect way to unite the central dimensions of everyday life in the kitchen and offers absolute planning reliability.



A system for greater individuality

The fronts of the drawers have a height of 144 mm. This measurement represents the fundamental unit on which our grid system is based: High enough to store any kitchen utensil in a drawer, but narrow enough for a refined, elegant look.



More storage space – even more convenience

XL heights provide 10 % more storage space and permit fully consistent planning. This is possible thanks to a reduced plinth height: The space that usually remains unused in the plinth area turns into additional storage space.

So, even with a comparable working height, it is not just possible to make an ergonomic plan but one that is optimised for more storage space, creating the ideal foundation for customised kitchen solutions with maximised convenience.

LINE N LINE one

LINE N – top-quality, innovative, handleless

Handleless kitchens exude particular calm and mesmerise with a design that focuses on the essentials.

The LINE N range offers a vast variety of design options.

The recessed handle can be planned tone-in-tone with the front or as a colourful highlight. LINE ONE expands LINE N with the push-to-open technology of the nBOX drawer system, while maintaining its design versatility. Optional lighting in the recessed handles creates a beautiful ambiance and highlights the handleless design. Clean lines and sophisticated details permit customised kitchen solutions.

**Handleless kitchens –
clean lines, minimalist look,
absolute beauty**



UNIQUE INNOVATIONS

AWARD-WINNING QUALITY

Our product developments and designs have won multiple well-known awards for their special features and their look. These prestigious awards do not just highlight our high quality standards, but also the innovative design and first-class function of our products. You too can benefit from our award-winning product innovations.

XTRA

Worktop – extra robust and elegant

Xtra worktops offer stylish elegance and practical advantages. Their innovative functional layer makes the worktop highly waterproof, extremely impact-resistant, and gives the worktop a particularly strong 3D structure. This also makes flush installation of hot plates and sinks possible. The Xtra laminate surface also increases durability. In a thickness of 38 mm, it comes equipped with an antibacterial microPLUS® surface.

The Xtra worktop has won multiple awards – among them the German Design Award Gold 2020 and the Red Dot Design Award 2018.



reddot award 2018
winner

XTRA CERAMIC

**Xtra Ceramic – genuine ceramic material,
excellent innovation**

The 16 mm thick, patented Xtra Ceramic worktop combines 6 mm genuine fired ceramic material with a light-weight support layer made of recycled PET. The innovative composite concept reduces the weight, simplifies assembly and reduces CO₂ emissions during transport. The pore-free surface is waterproof, resistant to staining, scratch- and heat-resistant, hygienic and easy to clean – the ideal surface for kitchens and bathrooms. The impact-resistant design edge ensures lasting elegance, and flush installation of hot plates and sinks is no problem at all. Xtra Ceramic is available in ten high-quality décors, for beautifully coordinated combinations. The matching 16 mm thick niche claddings complement the program. The quality of this development is certain to convince customers, as it has convinced the juries of the Red Dot, the Green Product and the Kitchen Innovation Award.



reddot winner 2022



Green
Product
Award
Winner
2022

XTRAHob

The innovative hot plate extractor fan

The Xtra Hob hot plate extractor fan combines elegant design with great functionality. In the grey slate, bronze and matt black version, it melds seamlessly into the worktop. The matt black variant features scratch-proof Onyka ceramic glass from EuroKera – a specially treated surface that remains free of marks even with intense use. Combining the grey slate version with worktop décor 373 grey slate reproduction makes for a particularly beautiful design: The Xtra Hob becomes a practically invisible part of the surface, emphasising the concepts of contemporary home design with its subtle look and feel.



reddot winner 2022

MARKETING

FROM A SINGLE SOURCE

Our aim is to offer retailers the full range of kitchen products, covering all groups of merchandise. We supply our partners with the entire commission, from start to finish. One product range, one order, one delivery. This optimises processes, reduces complexity and saves processing costs. At the same time, nobilia processing the full order reduces the risk of errors and therefore the risk of complaints.

Accessory options for fully coordinated kitchen design

From intelligent storage solutions through beautiful mood lighting to highly modern shelving systems, we offer an extensive range of options to furnish your customers' kitchens to perfection, down to the smallest detail - both in function and in style. With us, you will find a suitable solution – from a single source – for any need and wish your customers may have.

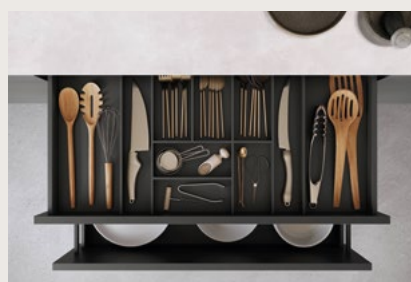



- Furniture, accessories and electric appliances all from one source
- One order, one delivery
- Comprehensive product range for all price segments

An extensive appliance range for any need

A broad range of electrical appliances including exclusive and high-end brands covers all price levels from entry-level to the premium segment. Exclusive nobilia models, among them Bora, Bosch and Siemens as well as in-house developments such as the Xtra Hob offer you unique selling points for marketing in the kitchen and furniture business.

Numerous
appliances for
any budget



For more information
about our brand partners, visit:
[www.nobilias.de/en/products/
electric-appliances/](http://www.nobilias.de/en/products/electric-appliances/)

3

COMPREHENSIVE FURNISHING SOLUTIONS





“You need to keep an eye on the market at all times to generate new impulses.”

Matthias Keudel,
Director Export

THE SYSTEM SUPPLIER FOR MORE THAN KITCHEN

Individually planned kitchens with highly automated serial production – our expertise as a market leader offers enormous potential. For surprising synergy. For related products. For new markets.

As a family-owned company, we consider it particularly important to be close to people. After all, you need to understand people and markets to develop products that people will love and that will make them feel at home. That is why we remain focused, at all times, on developing societal trends and changing needs among our partners and consumers.

The kitchen as the heart of the home has increasingly opened up. We have deliberately developed our product range to accompany this development. nobilia's range has long grown beyond just the kitchen segment. Our experience creates synergy effects that turn every room into a success. We bring our core and planning expertise in the kitchen segment with us into all other product ranges, creating an intelligently structured portfolio that comprehensively covers all rooms. That is what we mean by more than kitchen!

Comprehensive
furnishing solutions
from a single source



Our product range: more than kitchen

We offer high-quality furnishing solutions for the entire home. The ability to furnish the rooms used most intensively every day, the kitchen, bathroom and living room, in the same style is just the first step. From functional concepts for utility rooms, through wardrobes, storage space behind sliding doors and bedroom furnishings to cleverly arranged spaces for working from home – our products offer countless ways to supplement our core expertise of kitchens. This approach is one that we have strategically expanded over years and we are committed to keeping an eye on developments beyond the kitchen segment at all times.





- Comprehensive furnishing solutions
- Everything from a single source



All the options: Additional turnover thanks to additional product groups

More than kitchen will help you, as a kitchen specialist, expand your available product range and create real added value for your customers. As a planning expert, you can easily furnish adjacent rooms as well, thereby generating additional turnover using the familiar planning and order processes.

You can find all necessary items in the “more than kitchen” chapter in our Sales Manual. These options create synergies that will boost your sales.



One Sales Manual – one list – one logic

nobilia offers maximum flexibility and a clear overview, not just in products, but also in documents and ordering methods. The Sales Manual contains chapter nine “more than kitchen”, a focused overview of all product groups that go beyond conventional kitchens. The digital Sales Manual permits quick access to our full product range.

This means no bothersome switching between different documents – you can get everything from a single source. For plans with a consistent logic.

Moreover, the Sales Manual contains predefined planning examples for bathroom and living room furniture.

YOUR RELIABLE PARTNER FOR LIVING AND DINING ROOMS

While living rooms with many pieces of stand-alone furniture are a thoroughly different matter from a fitted kitchen, this does not faze us, a manufacturer who used to produce kitchen buffet cabinets. Our decades of furniture expertise make us a professional and highly capable partner in the living room segment, too. With our wide range of living and dining room furniture, we can develop opportunities for potential revenue together with you.

From sideboards, glass cabinets and coffee and dining tables to chairs – our versatile solutions don't just supplement kitchen showrooms, they are also perfect for creating independent living room concepts. High-quality materials and independent designs developed especially for living and dining rooms are just part of what we offer. We have positioned ourselves as an independent and sustainable provider along the entire value chain – from development to marketing – thanks to specialised employees.



**Optimised planning process:
nobilia planning data
integrated in furnplan**



Customised living room furniture, developed with planning expertise

Our living room furniture is sure to impress customers with a varied selection of décors in stylish designs and details and materials specifically selected for living rooms, such as genuine wood veneer. Robust elements such as the nBOX with its high load-bearing capacity meet even the highest standards – far beyond the usual standards for living room furniture in the industry. All furniture has been awarded the Golden M and is GS-approved, for safe quality in all living areas.





- Independent living room range incl. product lines
- In-house expert teams for Living segment
- Special marketing materials
- Comprehensive range incl. veneer

Our flexible order processing lets you choose from two simple options to match your preferred marketing method.



Free planning with individual components

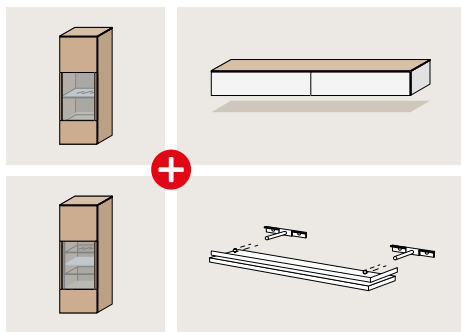

or

Quick orders using pre-configured sets and product lines

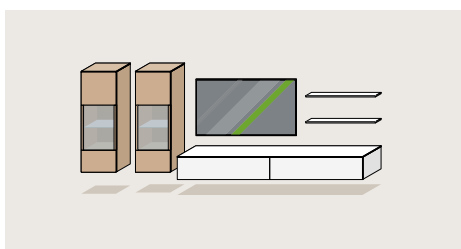

The system supplier with the all-round package for the living room segment

Our living room range is not just independent where products are concerned. The ordering and marketing processes are equally adapted to the needs of the living room segment: nobilia product data is stored in the furnplan planning system. The sales documents have been adapted to common marketing practices. Both, focused product lines with pre-planned combinations and a separate Living Sales Manual for free planning are available. The nobilia organisational structure is systematically designed for the living room segment.

From product development and product management through the Creativ Studio to marketing and sales, specialised teams provide support for the living room segment and help our customers with their specific marketing needs. We fully understand the living room segment as a merchandise group and communicate with our customers as equal partners in the marketing process.

PRODUCT DIVERSITY AND QUALITY FOR THE BATHROOM

Bathroom furniture requires true furniture expertise – and that is our strength. For years, nobilia has set standards by offering furniture with exceptional workmanship that meets even the highest standards for bathrooms. Nowadays we offer a comprehensive set of services that leaves nothing to be desired: customised products, matching accessories, separate sales documents, specialised bathroom experts in product development and sales and tailor-made marketing materials. Choosing nobilia means choosing expertise, quality and innovation – all from a single source. What bathrooms need is a solution that fits, from start to finish. Our extensive range of furniture is supplemented with taps, top-mounted and flush-mounted hand basins, mirrors and lighting solutions, meeting both aesthetic and functional needs.

From a guest bathroom
to a fully-fledged wellness
bathroom – everything is
possible



Versatility and tailored planning options

The wide range of surfaces, décors and materials nobilia brings from the kitchen segment means an enormous range of options is available for bathrooms. Our product range also complies with special requirements such as IP 44 certification – for sophisticated solutions down to the smallest detail. And all of it is based on a system that has long proven its value in the kitchen segment. This makes every bathroom plan precise, flexible and straightforward.





- Independent bathroom range incl. product lines
- In-house expert teams for bathrooms
- Special marketing materials
- Comprehensive range incl. ceramic material, taps and mirrors

Our flexible order processing lets you choose from two simple options to match your preferred marketing method.



Free planning with individual components

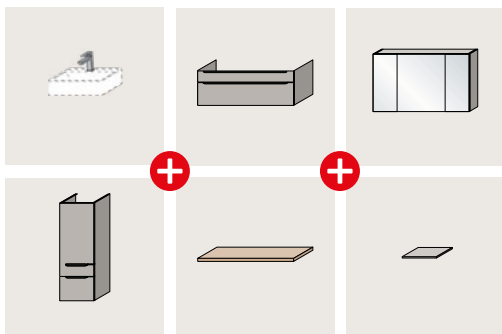

or

Quick orders using planning examples and product lines

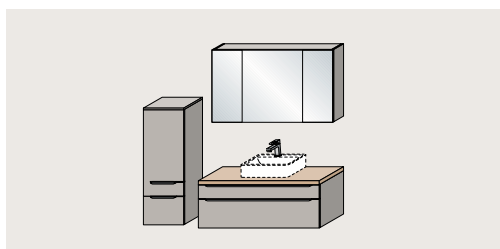

The system supplier with the complete service range for the bathroom segment

Impressive know-how: Our bathroom product range offers versatile planning options and high-quality accessories for efficient implementation of customised bathroom concepts. The required planning data is integrated in furnplan. Special sales documents for bathroom product lines with guided combination options help you with pricing and simplify the sales talks. In addition, the separate Bathroom Sales Manual offers a huge selection for free planning. With specialised bathroom experts in product management, sales and marketing, nobilia creates customised services and solutions that will boost your success and will satisfy your customers.

4

COMPREHENSIVE SERVICE FOR OUR PARTNERS





“Reliable service is not an add-on for us, but an essential part of our quality commitment.”

Eric Thomas,
Director France & Switzerland

BUSINESS SUCCESS THROUGH EXTENSIVE SUPPORT

We know that time and energy are the most valuable resources. That is why we are always by your side, offering comprehensive services – from complete marketing through cross-media concepts such as POS materials and digital marketing modules to training courses at our assembly academy. We will help you optimise business processes, so that you can focus on your core business. nobilia is more than just a manufacturer – we are your partner for a strong market presence and efficient daily business.

Personal support by
dedicated contact persons



Business transactions are always concluded with a human touch – by people who give them their personal attention and remain accessible.

Long-lived partnerships depend on trust and reliability. That is why we deeply value personal contact and consistent communication with our customers. At nobilia, personal contact partners offer individual support. Worldwide, over 120 colleagues in our field sales team support our partners directly on site – on the level of organisations, branch offices or individual customers. More than 300 experienced customer support employees in our inside sales team as well as specialised sales experts make sure your orders get processed without problems.

Our key account and field service colleagues keep a close eye on all important key data and work with you to develop tailor-made solutions – regionally and internationally. We always treat our partners as equals and our collaboration involves much more than simply determining terms and conditions. We will support you by providing a wide variety of measures: from sales documents and marketing tools through showroom planning to training programs and eCommerce solutions.



- Dedicated personal contacts in internal sales and field service
 - Communication in 22 languages
 - Individual support
-



- All services available 24/7 through our extranet
- Always available: order data, delivery times, reports
- Marketing and sales documents can be accessed digitally



nobilia extranet

Always by your side online – our extranet

The nobilia extranet is your central contact point for key information and smooth business processes. It gives you access to delivery times, order data and complaint reports at any time to optimise order processing for you. A wide range of services from sales documents for download to campaign marketing will help you establish a strong marketing presence. In addition, the extranet offers access to our training program with in-person workshops and webinars for experts, new employees and career changers.



Ask your field service contact partner for your extranet access data
extranet.nobilia.de/en/

Efficient consultations and planning – with the Digital Sales Manual (DVKH)

The Digital Sales Manual (DVKH) offers smart access to all relevant product and planning information – at any time and on any digital device. Convenient search and filter functions make it easy to find and compare products. Accessory recommendations simplify planning, particularly for people new to nobilia. It is free of charge, always up-to-date, sustainable and the ideal tool for flexible consultation, be it at your showroom or on the go. Every two weeks, nobilia offers free-of-charge webinars to teach you how to use the Digital Sales Manual.

Check out the Digital Sales Manual

Request your access data:
Digital_Manual@nobilia.de

FROM BRAND EXPERIENCE TO SALES SUCCESS

Successful sales start with the right documentation. Clear messages, a structured approach and well-planned materials are available to support you in your consultations and strengthen your presence at the Point of Sale. From journals and magazines through specialised sales and planning manuals to supplementary digital content, nobilia offers an extensive portfolio for convincing your customers. These documents are available for you to use systematically in your sales activities and create a solid foundation for efficient consultation and sustainable sales success.

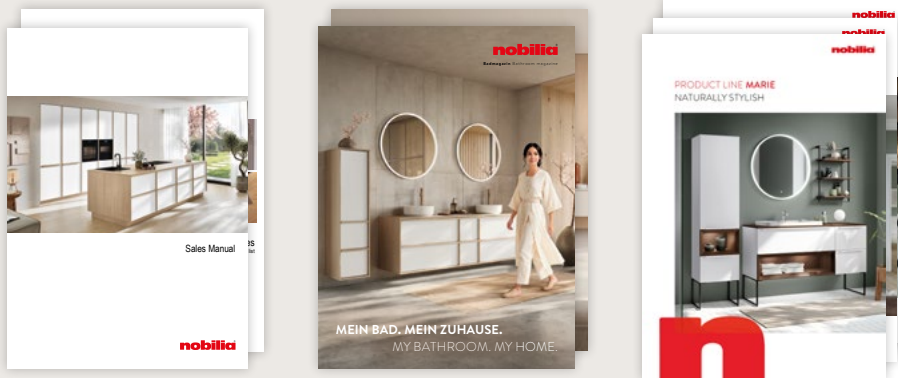

Sales made easy

Our journals and magazines offer inspiration and support in the planning and purchase decision phase – in printed form or as a digital eMagazine with additional content. During consultation, suitable sales documents make it easy to start making specific plans: In addition to the overall Sales Manual, specialised manuals are available for freely planned bathroom and living room concepts. Focused product lines for bathrooms and living rooms complement our portfolio and ensure quick, efficient consultation and successful sales at your showroom.

From inspiration to systematic consultation,
with perfectly structured sales documents

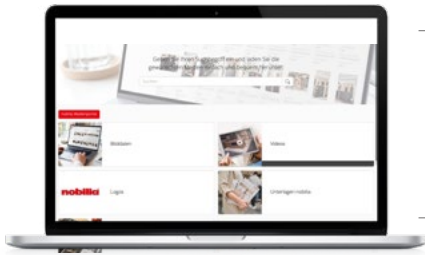

The nobilia media portal:
Up-to-date images, videos, logos and documents are available for direct download in the extranet.

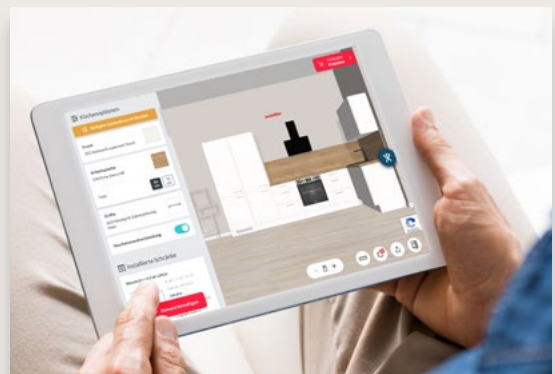

furnplan offers the perfect support for furniture planning

furnplan is the sales-supporting planning tool for the bathroom, living room, bedroom, wardrobe, utility room and office areas. nobilia offers its retail partners more than just access to nobilia product data within the software. We also actively support them with planning and configuration. This means nobilia partners benefit from precise, up-to-date planning data that simplifies sales and optimises the consultation process.

Efficient planning and precise data to ensure your success in sales

nobilia eCommerce for your digital success

nobilia supports retailers through tailor-made digital solutions – from website and webshop module kits through content and performance management to training courses. Our aim is to give you the right tools for a successful online presence. For implementation, we collaborate with RMTSoft, which specialises in digital solutions for kitchen retailers.

Contact us now via your nobilia contact person or nobilia@rmtsoft.de

RELEVANT CONTENT FOR GREATER REACH

From new products to current nobilia news – our social media channels are strategically selected to accompany our joint customers in the inspiration phase of the customer journey. With systematically selected content on Instagram, Pinterest and YouTube, we attract attention, create the impulse to buy nobilia products and keep nobilia present – close to your customers and with relevant content at all times.

Maximum reach to help you achieve success

Every day, nobilia reaches millions of people through its own social media channels. In the inspiration phase prior to purchasing new furniture, customers look for tips about how to plan with our products, how to use them, how to furnish a room with them – that is where the focus of our content lies. We target your customers systematically, supplemented by company news. Benefit from our strong online presence as a trust-building element in your sales.

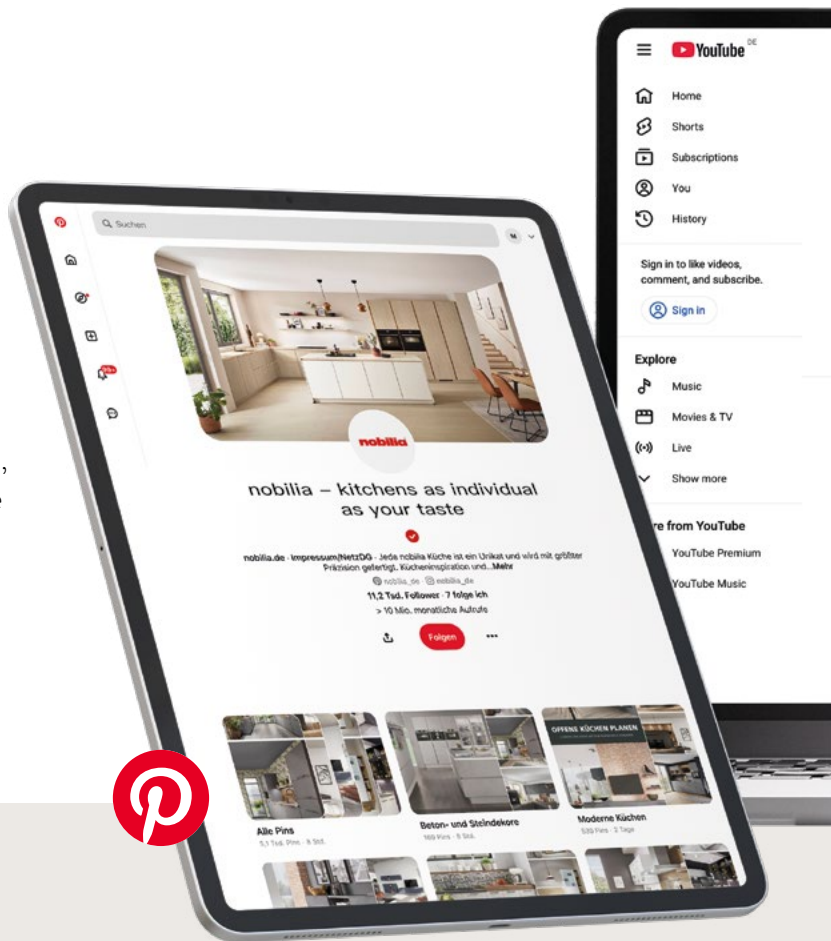

Pinterest

11,400 followers
~10 million impressions per month

Content:
Inspiration



Discover the world of our brand on Pinterest
https://de.pinterest.com/nobilia_de/

Instagram

66,800 followers
~10 million impressions per month

Content:
Inspiration, brand content, quick news



Experience nobilia highlights and news on Instagram
https://www.instagram.com/nobilia_de/

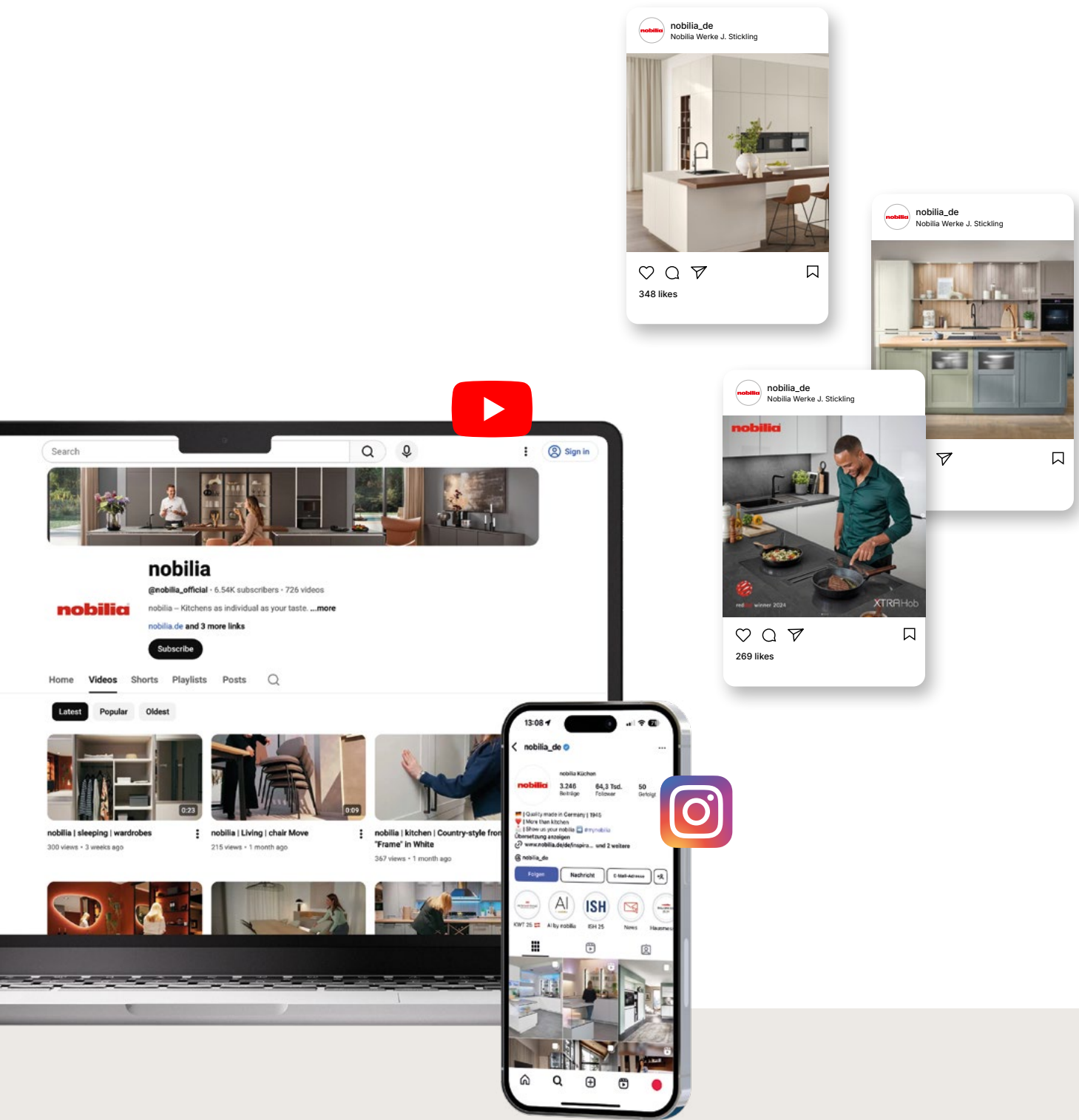

YouTube

6,000 subscribers + **500,000** impressions per month

Content:

Inspiration, brand content, tutorials (assembly)



Experience our brand presence and the world of our products on YouTube
https://www.youtube.com/c/nobilia_official



LIMITLESS OPTIONS THANKS TO DIGITAL SOLUTIONS

Digitalisation opens up new potential for efficiency, customer contact and success in sales. nobilia supports its retail partners through the use of modern planning aids, AI-assisted tools and powerful eCommerce solutions. Be it webshops, intelligent kitchen planning or support in your business processes – we offer digital tools to make your everyday work simpler and strengthen your sales in a lasting manner.



AI
by nobilia

The kitchen inspiration of the future – Enter the future with nobilia AI

Since 2019, nobilia has been investing heavily in Artificial Intelligence (AI). Our aim is to optimise our own processes – but first and foremost, to support our retail partners with innovative tools. nobilia is in contact with all leading software providers for planning systems to permit quick, seamless integration of our AI solutions into existing systems – to give you the greatest benefits.

AI-assisted solutions for inspiration and planning – including for consumers

Discover the future of kitchen planning with our innovative solution that uses AI to fascinate your customers and simplify your work. As an addition to your website, the planning tool lets consumers plan their dream kitchen in just a few clicks. The customer then sends the final plan to you together with their contact information – as a highly-qualified lead with a specific planning template. image create is an application that can already be integrated by retailers: AI-generated images give customers quick inspiration matching their furnishing preferences. Appeal to end customers in a playful manner, using familiar functions: “swishen” is the world’s first “kitchen dating” experience – for your website! Fascinate your customers with a playful experience that guides them, step by step, to their personalised dream kitchen: The user simply swipes left or right to indicate whether they like the kitchen they are seeing, creating a personal taste profile with this method.



AI-assisted inspiration by nobilia
<https://www.nobilia.de/en/inspiration/ai-worlds-of-ideas/>



“Kitchen dating” with swishen
<https://www.nobilia.de/kuechen-dating>



RMTSoft offers digital processes for kitchen retailers

Efficient planning and precise data to ensure your sales success

nobilias has taken a step further with its partner company RMTSoft, offering customised software solutions for the entire sales process. From the cloud-based ERP system WORKX through the warehouse management program STORAGE to the electronic assembly acceptance log via app (MSA) – RMTSoft optimises your everyday work in the digital realm and creates clear structures for greater efficiency.

Take, for instance, this exceptional example: The automatic planning review ATAK checks orders for plausibility within seconds. If used regularly, the program demonstrably reduces planning errors by up to 80 %, leading to fewer complaints and a more secure profit margin for our retail partners. RMTSoft is an integral component of the nobilia network. Services can be booked directly through RMTSoft.

- WORKX
- ATAK
- STORAGE
- MSA
- E:COM
- K:PLAN
- LIV:K



Find out more about merchandise management, planning review and the service app
<https://www.rmtsoft.de/en/products/>



Our digital solutions in the extranet
<https://extranet.nobilias.de/en/services/digital-business-solution/>

YOUR BRAND. OUR STRENGTH.

If, as a retail partner, you would like to receive not just products but an entire sales concept from nobilia, we will support you by providing comprehensive retail concepts. Our established brand shop solutions, marketing support and training concepts are all part of an all-round package helping you present yourself successfully in kitchen retail. This will allow you to establish your own brand in retail, supported by the quality standards of nobilia kitchen production.



Store brands with nobilia quality

All products are manufactured in the established nobilia system production and meet the same high quality standards. High-quality materials, state-of-the-art technologies and precision workmanship define nobilia's production. At the German production sites, kitchens are manufactured in digitally networked and highly automated production processes, that are precisely controlled and consistently monitored. All of this is based on nobilia's time-tested production and system expertise. This is how we unite individual brand presentations by retailers with the quality of nobilia furniture production.



- Established brand shop concepts for kitchen showrooms
 - Support with shop and exhibition concepts
 - Salesperson training and development courses
 - Marketing concepts for a strong brand presence
-

nobilia RETAIL.

MORE THAN JUST THE PRODUCT.

If you want more support than just buying the product from nobilia, we have our own retail brands. They offer services that include training for sales teams, support with shop and showroom design, and marketing measures to ensure a consistent brand presence.



Based on franchise or brand licensing agreement, the nobilia retail brands form a strong international network with over 1,000 stores in over 20 countries.



You would like to know more about nobilia's retail concepts or are interested in collaborating with us?

Please do not hesitate to contact us at: retail@nobilia.com

PERFECTLY PLANNED SHOWROOMS BY OUR EXPERTS



**The nobilia
Creativ Studio
offers tailor-made
showroom
and trade fair
concepts**

To convince customers of a product, they must experience it. Our Creativ Studio is staffed by experienced interior designers and specialises in providing precisely that experience: In close collaboration with you and your field service contact partner, we create showrooms that meet all of your needs. Knowing the target group and the local market is crucial in this process – from the latest kitchen and living room trends to consumer preferences, our experts always keep a close eye on the market. The result is the creation of floor plans, showroom kitchens, complete kitchen and bathroom exhibitions and inviting living spaces that are perfect for promoting sales. Our assembly management coordinates around 20,000 assemblies a year, with the support of 140 assembly partners and 19 factory fitters employed by nobilia itself. Beyond your showrooms, the Creativ Studio also organises entire trade fair booths – nobilia's in-house exhibition is its largest yearly project and our greatest reference.



- We design showrooms that inspire
- Interior design following the latest trends
- Experience nobilia live at the in-house exhibition



Inspiration and information live on site

Experience the world of nobilia at our comprehensive exhibition at our company headquarters in Verl. In a space of over 5,300 square metres, our experts of the nobilia Creativ Studio present an inspiration and information centre with a fully new design each year. Each year, we welcome over 17,000 visitors from all around the world. Come visit us and witness our planning expertise and the staging of modern showroom concepts first-hand.

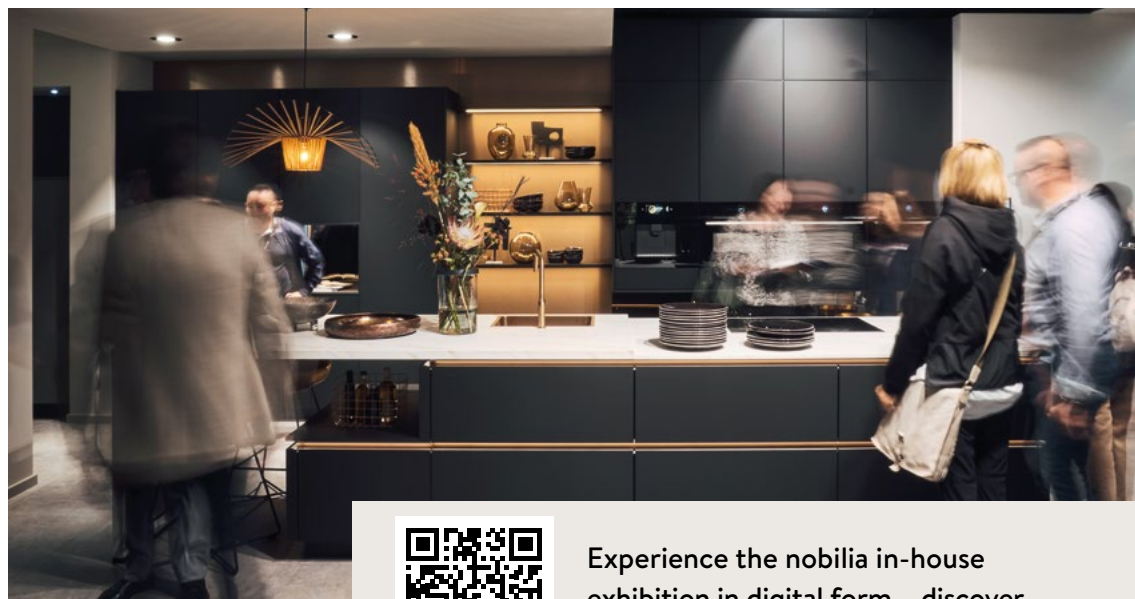

Experience the nobilia in-house exhibition in digital form – discover us online!

LARGE BUILDING PROJECTS WITH A SYSTEM IMPLEMENTED WITH GREAT EFFICIENCY

Large projects have particular requirements for planning, production and logistics. If numerous identical or similar furnishing solutions are required with a fixed deadline, the needs of the project are completely different from conventional commissions. In addition to kitchens, furniture for bathrooms and storage solutions like wardrobes are also frequently required. That is why nobilia has its own workflow for large building projects. This ensures reliable planning, production and timely delivery, even for large quantities of the same or similar furnishing solutions.

Comprehensive project planning from a single source

In large building projects, orders are not processed separately. Instead, we group all orders of one project and manage them together. This allows us to pool the required quantities, materials and production capacities early in the process. At the same time, we identify how to best implement the project – for instance by producing the required products in a single plant or simultaneously in multiple plants.



Raffles City in Chongqing, China with 1,600 kitchens

Early planning for stable processes

Large project quantities cause production peaks outside of the regular rhythm of orders. That is why we review material availability, supplier capacities and production schedules early and comprehensively. This forward-looking planning procedure allows us to detect potential bottlenecks early and develop a suitable solution together with our customer. For instance, we can decide to adapt delivery dates or deliver individual components at a later time while the planned furnishing solutions are provided on schedule.

Reliable implementation even for large quantities

This structured project workflow allows nobilia to complete even extensive projects reliably. Production planning, inventory control and logistics work closely together, creating stable processes and ensuring high delivery reliability. In general, we consider any project with around 20 kitchens or more a large project. But this is just a guide value. Each project is evaluated separately, with plans made accordingly.

This makes it possible to produce and deliver even large quantities of identical or similar furniture on schedule, for instance for apartment buildings, hotels or office and company buildings.



- Comprehensive and flexible project planning for extensive projects
 - Early review of material and production capacities
 - Furnishing of complete building projects with solutions for kitchens, bathrooms and storage space
 - High delivery reliability even for large project quantities
-

OVERCOMING THE CHALLENGES OF THE FUTURE THROUGH TRAINING AND PROFESSIONAL DEVELOPMENT

In an industry that is always in motion and faces ever-new challenges, qualified personnel in planning, sales and assembly are the key to success. With our extensive range of workshops and training courses, the nobilia academy offers a tailor-made program with great added value for your everyday work. Our workshops and courses impart specialist knowledge about kitchens, bathrooms and living rooms – for personnel working in sales, planning and assembly, from beginners to experts.



nobilia academy – your centre for training and professional development

Our nobilia academy offers programs that adapt to your schedule. We are constantly expanding our extensive range of workshop and training options, so that we can always offer you the right option for your specific needs.

Various professional development options for any need

Our training options are as flexible as your business life. Whether in-person workshops at our training centre in Verl or personalised on-site training at your company premises – we offer tailor-made opportunities for training sales staff and fitters.

Our own trainers impart practical knowledge – in open or exclusive training courses, adapted to your needs. Our year-long workshop schedule combines theory and practice. nobilia offers excellent conditions for this:

Knowledge imparted in our own training spaces can immediately be tested on our products – in the large in-house exhibition, the concept showroom or the spaces of the assembly academy with a shop floor and an “assembly obstacle course”.





Learn wherever and whenever you want – on-demand webinars and live training courses

Intensive training courses and on-demand webinars for you and your team

Our on-demand webinars are a free-of-charge offer to sales personnel and fitters for flexible use from anywhere. Whether technical training, new products or sales promotion – the interactive and practical contents are easy to integrate into your everyday work. These webinars are available in German, English and French. Live webinars also include the option of talking directly to experts who can quickly answer any questions you may have.

Visit the nobilia extranet for a full program of training courses, an overview of costs and the option to book workshops directly. On request, we will develop exclusive professional development courses for you, adapted perfectly to your specific needs.



- Whether short or intensive: We have the right course for any need
- Our workshop program for anyone from beginner to expert

PERFECTED ASSEMBLY DOWN TO THE FINAL SCREW

Qualified fitters are essential for customer satisfaction. That is why our trainers at the nobilia assembly academy will train your fitters using tailor-made learning concepts to get them ready to achieve the best possible assembly performance. Our unique training centre at our company headquarters in Verl offers 2,800 square metres filled with the perfect prerequisites for professional training – with theory and practice, special training courses, courses of study certified by the Chamber of Industry and Commerce and webinars.



nobilia assembly academy – Practical professional development for fitters

Twelve topic-specific stations, an in-house shop floor and digital material provide a foundation for excellent professional development. The expert knowledge of suppliers and manufacturers is integrated directly into our program, making it truly comprehensive.

Our training courses combine theoretical knowledge with practical exercises and are based consistently on the requirements of everyday assembly. Your assembly teams will be able to expand their expertise systematically and optimise their skills in assembly processes.

We constantly expand our training program, incorporating current product developments and new technical solutions.





Practical training for assembly teams

**Tailored theoretical
and practical training –
unique and specialised**

The training courses at the nobilia assembly academy combine theory and practice. Fitters can learn assembly processes directly at realistic training stations and can immediately start using the new techniques they have learned.

Our aim is to work together with specialist retailers and fitters to ensure a high level of customer satisfaction through optimised assembly processes – true to the motto: A kitchen is only as good as the way it's fitted.

Inspiration in the nobilia Concept Showroom

Visitors to the assembly academy start their visit at the nobilia Concept Showroom.

This high-quality product presentation is nobilia's way to give its partners inspiration for their own showrooms.

At the same time, the Concept Showroom is an important learning platform for the assembly training, as the perfection shown here is the goal.



5

SAFETY THROUGH QUALITY





“From the time we receive an order, through processing, to delivery: We focus on our customer’s needs in every respect.”

Dr. Maik Schlickel,
Head of Quality Management

TOP QUALITY FROM THE GET-GO

If you produce and deliver over 3,900 commissions a day, you are bound to be aware of the importance of process reliability in all areas. That is why nobilia focuses on comprehensive, preventive quality management – maintained consistently throughout the entire process chain, from product development through production to delivery. This approach has helped nobilia win a secure position as the quality leader of our industry in the past years. Error prevention, precise analysis and lasting fault correction: Our testing and quality assurance measures set standards and guarantee long-lived, reliable products for consumers, with smooth processing and few complaints for you as a partner. And you can count on that.

Voluntary warranty for our retail partners

Reliable quality is the foundation of strong, trust-based customer relationships. For nobilia, the satisfaction of our retail partners is a top priority – and that means helping quickly and without bothersome paperwork, whenever it is needed. The consistently high quality level of our furniture is the foundation of a collaboration based on partnership and good will. To give our partners the best possible support, nobilia offers a voluntary warranty of 10 years on all furniture parts produced by nobilia – this applies to kitchen furniture as well as all living room and bathroom furniture.

10
YEAR
GOODWILL



Quality in each step of the process

Our Quality Management employees ensure that strict quality standards that go far beyond national and international requirements are maintained in all areas – from customer service and supplier management to production inspection and laboratory testing. In addition, we conduct regular product and supplier audits as well as audits of unloading processes and returns. These audits analyse processes, uncover weaknesses and help us develop joint solutions – both with new suppliers and during regular audits of existing suppliers. This does not just maintain our product quality and reduce the rate of complaints we receive, it also increases the efficiency of our supply chain.



QM testing lab

We make sure that our furniture is fit for daily use. At nobilia's own QM testing lab we put our products through their paces. We make the work we put into this process and the diversity of testing methods for our products and new developments transparent to our customers: The "glass laboratory" at nobilia's in-house exhibition offers 230m² of insights into the sophisticated tests that each product must pass before serial production can start.



Maximum standards

nobilia's stringent quality standards go far beyond the required national and international standards. The endurance testing devices at our QM testing lab test the furniture to ensure it has a minimum lifespan of 15 years. This means we put significantly more strain on our furniture than required by the relevant DIN standard. In addition, we regularly have independent testing of our products and processes conducted by external institutions. The results say it all, as you can see from our official seals of quality and certificates. From standardised product requirements such as the DIN ISO standards to the Golden M to the GS label for tested safety, nobilia meets even the most stringent requirements.

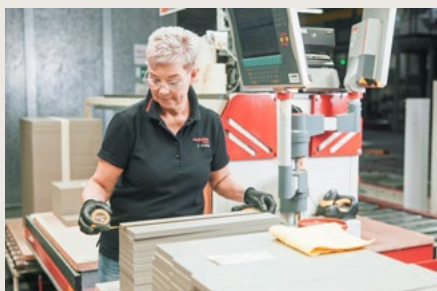

Testing during production and QM testing stations

In order to maintain the same high serial production quality after market launch, we conduct testing during production of furniture and individual components at specific, pre-defined intervals. Strict tests are firmly integrated in our production process and ensure high quality in each phase at various testing points. Our daily serial process monitoring is conducted through manual testing, such as the front check at the cleaning stations, but also through technology-supported in-line monitoring using AOI (automated optical inspection). We rely on an optimised combination of innovative technology and human expertise.

INNOVATIVE PRODUCTION WITH A SYSTEM **MADE IN GERMANY**

What started as a small craftsman's establishment with seven employees in 1945 has grown into Europe's largest producer of kitchens. Those first small workshops have turned into a company that sets new standards for modern furniture production. In four state-of-the-art factories, 4500 employees produce our furniture, exclusively in Germany – at the most modern location in Europe. This consistency of location is a strategic decision and an expression of our high quality standards. Consistent investment in production processes, automation and process reliability ensures that we don't just maintain high standards, but keep developing them further.



Made in Germany

High-quality materials, state-of-the-art technology, perfection in craftsmanship and production with a system. Our production is digitally networked, highly automated and precisely controlled and audited – a reflection of time-tested nobilia expertise.

For us, “Made in Germany” is a practised commitment to our home location. Around 80 % of our suppliers are from Germany, half of them from the region around Verl. At the same time, we deliver globally with an export rate of over 50 %. nobilia production represents process reliability, a zero-error strategy, low complaint rates and cost leadership thanks to high quantities, optimised processes and efficient logistics. An intelligent modular system allows us to maximise customisation while maintaining attractive prices.



- Largest producer of fitted kitchens in Europe
- Four plants, one promise: maximum reliability in delivery
- Kitchens, bathrooms, living rooms.
Quality made in Germany

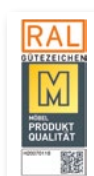



Plant I - Sürenheide

Plant III - Gütersloh

Four highly-automated plants in Germany

Four plants
for maximum
efficiency and
quality

nobilia produces in two-shift operation at four locations with a total production area of 439,000 square metres. The plants located in Verl-Sürenheide, Verl-Kaunitz and Saarlouis are independent production sites and have identical vertical integration. All three plants produce kitchen, bathroom and living room furniture. This means the products for different room plans can be delivered together. Plant III offers additional resources to increase volumes and reduce complexity in Plant I. To establish perfect logistical connection, nobilia has had its own motorway bridge constructed across the A2 (motorway), reserved entirely for use by nobilia plant traffic. The location in Saarlouis in the Saarland region has been selected strategically to serve key markets in southern Europe with optimised logistics. nobilia's redundant production capacities allow us to offer high delivery reliability with a low risk of failure, making us an exceptionally reliable partner.



Plant II - Kaunitz



Plant V - Saarlouis

EACH COMMISSION IS UNIQUE

CUSTOMISED FURNITURE IN SERIAL PRODUCTION

Efficient processes, state-of-the-art technology and top precision – these are the things that go into each and every piece of nobilia furniture. An intelligent production management system and highly automated production ensure that the customised solutions for kitchens, bathrooms and living rooms are manufactured without interruptions, on schedule, and in a resource-friendly manner. From raw panels to the finished piece of furniture, all processes interlock perfectly, while extensive quality testing guarantees first-class standards.

Quick and complete, through perfected automation

Customised furniture,
produced in series:
Highly automated
production of unique
pieces has made us the
market leader

nobilia represents quality, versatility and reliable kitchen production worldwide. These days, bathroom and living room furniture is also part of our product range. Market shares like these require exceptional production performance: Our plants can manufacture up to 38,650 units per day. The level of efficiency required for these quantities is immense. Automation means more than just completing material processing with programmable machines. So yes, we cut the large wooden boards with an IMA-Schelling saw and complete the visual quality checks using high-performance cameras. But the intermediate steps of adding value are equally machine-supported: For instance, our high-bay warehouse in Plant I has more than 27,000 pallet bays. Fourteen fully automatic storage and retrieval machines (SRMs) are used for moving pallets at this location. By the way, the motors of the SRMs are used as dynamos to generate electricity during braking and descent. This is comprehensive product design.

From delivery of the raw board through part production and carcass and front pre-assembly to parallel worktop production, long piece production, assembly and finally packaging of accessories: Each piece of furniture we make has been ordered, and we only produce to order. This means no storage space is taken up by pre-produced units. nobilia products are manufactured and immediately loaded into the lorry. Everything required to complete the solution for the customer is added and transported to you in one delivery. Whether kitchen appliances or bathroom taps: You will get everything from one source, packaged in one plant. nobilia's expertise in kitchen manufacturing has made us a system supplier for the entire home.



- Lean and efficient production processes
 - Extensive quality monitoring, from the suppliers to delivery
-



Long-term partnerships with suppliers

Good furniture production is based, among other things, on good suppliers. We maintain close, long-term partnerships with our suppliers, based on mutual trust and dedication by both parties.

Over half of our suppliers have been working with us for over two decades. This partnership permits continuous improvement of delivery processes and even joint product development. That is how we turn high-quality components and joint experience into first-class final products.

Our production capacities in numbers



439,000m²
production area

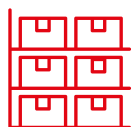

855,000
kitchens per year



3,900
kitchens per day

DELIVERY WITH TOP RELIABILITY

Our standards of quality and customer satisfaction apply worldwide. Be it national delivery or international container shipping – we manage our logistical processes ourselves to the greatest extent possible, thereby securing consistent standards from loading to delivery. Our own nobilia vehicle fleet and a strong network of trained partners have allowed us to establish reliable supply chains inside and far beyond Europe.

Logistics with planning security

Smooth delivery processes thanks to in-house fleet of vehicles

We consider reliable logistics key to guaranteeing planning security and adherence to delivery schedules. Thanks to our own vehicle fleet, we have full control of key quality factors – from delivery quality to punctual delivery. This allows us to respond with flexibility to customer demands: specific delivery times, special customer requirements or coordinated goods acceptance times.

Our own nobilia vehicle fleet has achieved 97.24 % adherence to scheduled delivery dates – a record value for the industry. Over 500 drivers ensure professional delivery. Regular training courses maintain their qualifications: from driving safety and resource consumption through unloading techniques to digital on-board technology. During unloading, each delivered item is scanned. Data regarding missing items and complaints is transmitted to nobilia in real time – for immediate processing and rapid subsequent delivery.

Stable supply chains through mutual trust

But the human touch counts, too: If possible, fixed 2-person teams deliver to a fixed customer base, creating a reliable partnership where everyone can collaborate as equals. This allows us to ensure stable processes and plannable deliveries.

520
drivers

238
lorries

1,074
semi-trailers

15
countries we
deliver to

3.35 M m³
transport capacity





- Delivery by your own nobilia driver
- Long-term partnerships with qualified forwarding companies
- Problem-free transport solutions for international markets

International transports and export logistics for reliable delivery processes

**Global transports:
Sea freight,
air freight,
consolidated
transports**

For international customers, we handle transports far beyond Europe. In addition to our own vehicle fleet, we offer sea freight, air freight and flexible consolidation of deliveries, thereby providing requirement-specific solutions irrespective of the shipment volume. Export deliveries are generally conducted FOB German sea port. For air freight it goes without saying that nobilia also handles the packaging in line with all the requirements.

Our customs department accompanies all exports outside of Europe, ensuring complete, professional document processing, including digital documents such as electronic certificates of origin. Moreover, we provide support with country-specific requirements and will help you select suitable logistics partners.

In addition to our own vehicle fleet, we partner with qualified forwarding companies that work according to the same nobilia standards our own drivers use. Deliveries are also completed using standardised processes: nobilia equipment digitally records and documents the unloaded items.

An annual freight volume of 3.35 million cubic metres requires powerful, sophisticated logistical concepts for international transports. For a large percentage of our exports, container transport is the preferred shipping method. Use of long semi-trailers and 25-meter Giga Liners, intermodal transport on road and rail and optimised route planning all help maintain our high delivery standard.

SHAPING A SUSTAINABLE FUTURE

As an independent, family-owned company with a forward-looking approach, nobilia takes responsibility for environmental and social matters. Our strategies aim to keep our company, our employees and their families healthy in the long term. We are confident: Sustainable action and social dedication help secure long-term economic success. That is why we operate in an energy-efficient manner, protect resources and invest in sustainable technologies. From production, to logistics, to infrastructure – our aim is to become CO₂-neutral. To achieve this aim, we take extensive measures: from product developments through establishing a circular economy to setting up our own photovoltaic power generators.

Award-winning sustainability: Recycled materials

Recycling is key to resource-friendly production. The particle boards used by nobilia are 70 % recycled material. Our in-house developments also follow this principle: Our patented Xtra Ceramic worktop combines a robust ceramic surface with a base layer made of 100 % recycled PET bottles. That reduces its weight and lowers CO₂ emissions during transport. This composite material concept is unique and has received the Green Product Award 2022.



The life cycle of a nobilia kitchen

Acting in ways that keep life on our planet worth living, now and in future – that's how we understand sustainability at nobilia. That is why we take a hard look at each phase in the life cycle of our furniture. Every single aspect along the way – the raw materials, supply chain, production, transport, retail and durability – offers potential for creating a future that's worth experiencing. We also address concepts for disposal of unavoidable waste. Our sustainability journal explains in detail, which sustainability measures we have initiated.

Award-winning product ranges

Many of our product ranges have the “Blue Angel” environmental label, a label awarded to products that meet strict environmental, health and consumer protection requirements. We are the first manufacturer in our industry to receive this label for multiple product ranges.



PV installation
Power from renewable energies

Trailblazer
As early as 2009, nobilia became the first kitchen furniture manufacturer to be awarded a PEFC certificate.



Conscious living

nobilia aims to reach CO₂ neutrality independently, without compensation from outside of the value chain.

One step we have taken in that direction: Producing power from renewable energies. In summer of 2024, the roof of Plant III was fully covered with a photovoltaic installation of the latest generation. With an output of over 2,300 kWp it would cover the needs of over 400 single-family houses – at nobilia we use it to cover our own power consumption. After all, production requires energy – and in future, we would like that to be green energy.



The sustainability journal

Scan now and discover what sustainability means to us.



**BECOME
OUR
PARTNER**





“With us, you will find collaboration that protects values, takes responsibility and promotes performance.”

Javier Lombardia, Head of South/
West Europe, Export Overseas

YOUR ADVANTAGES AT A GLANCE

Family-owned company

10 year
goodwill

nobilia academy

System supplier:
Furniture for the
entire home

Tested quality in an
in-house QM laboratory

Partner for
digital solutions

Independent
logistics

Showroom planning by
in-house **Creativ Studio**

Made in Germany





YOUR CONTACT TO A PARTNERSHIP BUILT ON TRUST

nobilia Werke
J. Stickling GmbH & Co. KG
Waldstrasse 53-57
D-33415 Verl
+49 5246-5080
info@nobilia.de
www.nobilia.de

nobilia[®]

Company brochure

 /nobilia_de

 /nobilia_de

 /nobilia_de

Unternehmensbroschüre

92700



EN

Contact Details

+973 17741155 | +973 32300608 | +973 39432044

 www.hajigallery.com

 info@hajigallery.com

 [hajigallery](https://www.instagram.com/hajigallery)

SHOWROOMS

Tubli - Seef - Segaya - Galali

حاجي جاليري
hajigallery